

HYDRAULIC CONCRETE PLACING BOOMS

# BSD 26/33

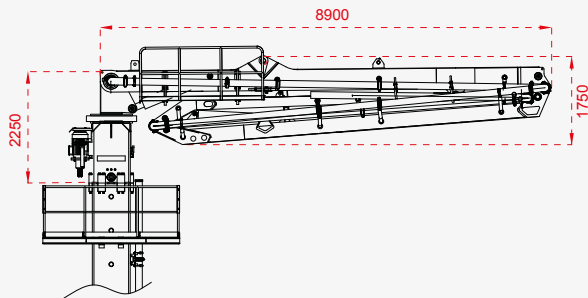

## ● TECHNICAL DETAILS



BSD 26 - 4ZT

## ● TECHNICAL DETAILS

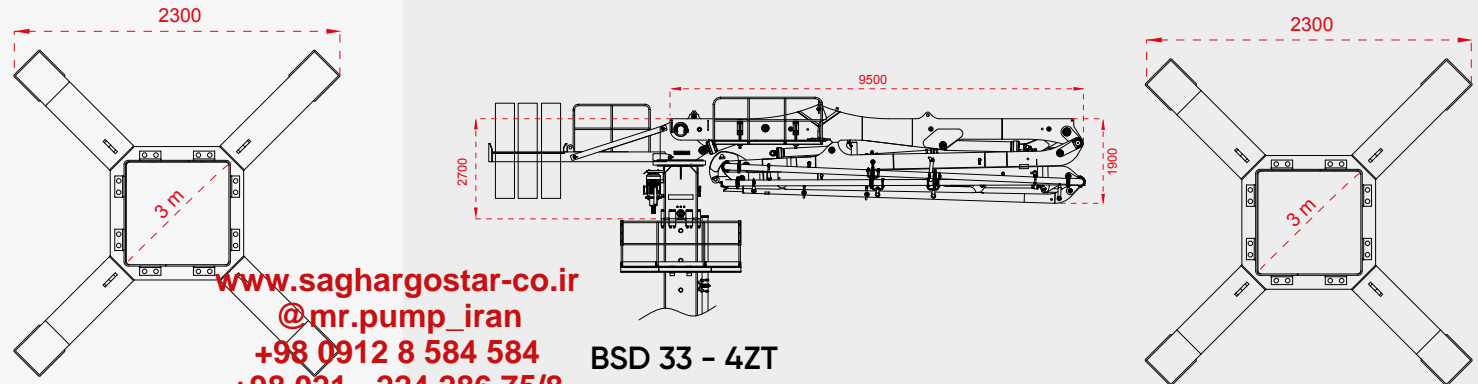

BSD 33 - 4ZT

[www.saghargostar-co.ir](http://www.saghargostar-co.ir)  
@mr.pump\_iran  
+98 0912 8 584 584  
+98 021 - 224 286 75/8

## ● BOOM SYSTEM

		BSD 26 - 4ZT	BSD 33 - 4ZT
Boom Type		4ZT	4ZT
Vertical and Horizontal Reach (max)		25,6 m	32,7 m
Boom Unfolding Height (min)		7,6 m	10 m
1. Boom Length		7,4 m	8,9 m
2. Boom Length		6 m	7,9 m
3. Boom Length		6 m	7,9 m
4. Boom Length		6,2 m	7,9 m
End Hose		3 m	3 m
Boom Swing Speed		113 sec	113 sec
Boom Swinging Angle		365°	365°
Concrete Pipe Diameter	(Inner Diameter) (Outer Diameter) 51/2" Flanges	125 mm 133 mm 148 mm	125 mm 133 mm 148 mm
Detachable Boom Weight	(TW) (1st Section) (2nd Section)	6,200 kg 2,300 kg 3,900 kg	8,990 kg 4,285 kg 4,705 kg
Column (10m)		3,580 kg	3,580 kg
Column (6m)		2,400 kg	2,400 kg
Column Support Frame		1,300 kg	1,300 kg
Drive		15 kW Hydraulic-Electric Motor	15 kW Hydraulic-Electric Motor

## ● STANDARD EQUIPMENTS

	Radio Remote	Radio Remote
Remote Control Unit	Radio Remote	Radio Remote
10 m Square Column	1 x	1 x
6 m Square Column	1 x	1 x
Working Platform	1 x	1 x
Floor Frames	3 x	3 x
Hydraulic Climbing Apparatus	1 x	1 x
Torque Spanner	1 x	1 x
Ladder Units	4 x 2 m (1 ladder unit per 2 m distance)	4 x 2 m (1 ladder unit per 2 m distance)
Optional	1 unit of transversal leg foundation base + anchorage bolts	1 unit of transversal leg foundation base + anchorage bolts

Placing booms are available on our production line as 16, 20, 36, 39, 43, 48 meters.

\* All datas shown are theoretical and subject to change without notice.

www.saghargostar.co.ir  
@mr.pump.iran  
+98 0912 8 584 584  
+98 021 - 224 286 75/8